



ZEUS STUDIO BUS
STUDIO GRADE EURORACK POWER

VERSION 1.1



- 1) Introduction: The Advantages of ZEUS
- 2) Understanding power consumption of your modules and the system
- 3) Attaching the Zeus Studio Bus to the case
- 4) List of recommended parts and part numbers (power socket, switch, connections)
- 5) The Tiptop-Cincon power supply
- 6) Power up for the first time
- 7) The wire connector and grounding
- 8) Planning a system 3U 6U and 9U
- 9) Planning large systems 18U
- 10) Planning very large systems 18U X 2
- 12) Mechanical specifications
- 12) Electrical specification and change log



ZEUS STUDIO BUS

Chapter 1 Introduction: The Advantages of ZEUS

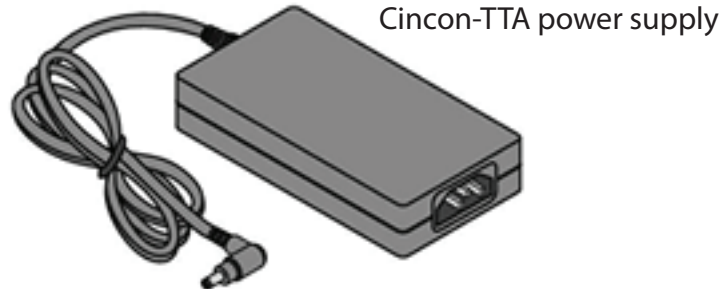

Cincon-TTA power supply

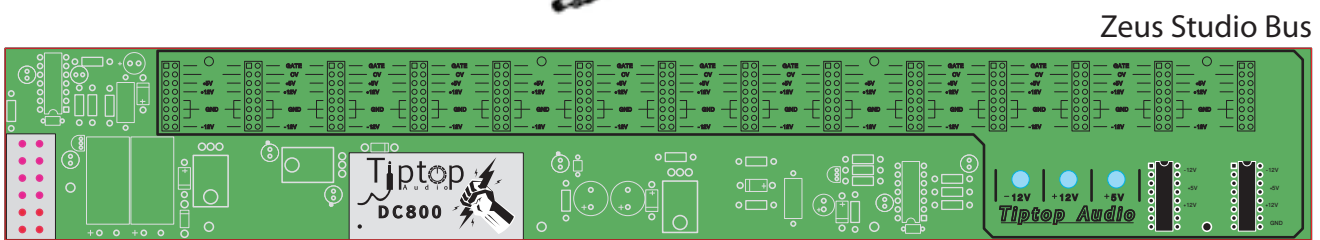

Zeus Studio Bus

Zeus Access

The ZEUS power system for modular synthesizers was developed to bring the advantages of today's modern power technology to the modular synthesizer.

The ZEUS power system, in most cases, will be comprised of an external wall or brick power supply and a Zeus Studio Bus board.

The safe and easy installation of ZEUS systems is its first and most obvious advantage. It is now possible to power a complete modular system from an external brick style universal power supply, the same power supply used to charge laptop computers. These external power supplies are extremely powerful and paired with the right combination of Bus Boards, even very large systems can be wired up with Zeus's top quality power.

Using an external power supply ensures your system stays light-weight and clear of electromagnetic emissions produced by transformers. In essence your case stays cool, safe, and most importantly removes any need to deal with hot AC main lines while installing the system.



(Continued...)



Introduction: The Advantages of ZEUS

The Zeus Studio Bus is the next generation of Zeus power technology and was designed to provide outstanding performance by combining the best of both worlds: the convenience of switch mode power technology and the robust regulation of linear power technology. The result is a power system that will feed your modules with strong and clean power for studio grade sound quality. As eurorack keeps growing more and more new manufacturers start offering modules and the challenge for providing a power system that is one solution to all had to be addressed with the best of power technology known to us; the Zeus Studio Bus was developed as the second generation of Zeus power to keep up with this reality, minimizing power problems such as bleed-through, ground noise, excessive power draw by modules and other problems known to us. When you look at the Zeus Studio Bus, it is easy to see the many components mounted on the board; all this circuitry is there to give quality power second to none.

In addition to the above advantages, the Zeus Studio Bus was also designed to allow new and more powerful modules to be developed, leading a path into the future of the upcoming Tiptop Audio modules and systems.

This manual will guide you through the steps necessary for you to design the power system that meets your needs, taking into consideration the power consumption used by today's modern modules, mechanical assembly and wiring, and ZEUS systems built with the intent of power/size expansion over time.

The Zeus Studio Bus makes wiring power into cases as simple as ever before with no need for special tools or complicated planning.



Chapter 2

Understanding the power consumption of your modules and the system

The power consumption requirements for today's crop of new and exciting modules varies from the prior needs of modules in the past. Before, the current draw was almost always even on both the positive and negative side of the rails. For instance, a 30mA module usually drew 15mA from the +12V rail and another 15mA from the -12V rail making for an even distribution of power consumption over the chain of power flow. This allowed the user to quickly calculate the necessary power supply specifications they would need to provide sufficient power to their systems.

Today this is not always the case. In modern modules there are far more digital technologies that require greater amounts of current drawn from the +12V power rail than what is drawn from the -12V power rail. With this in mind, the user can no longer take the summed mA total for granted and base their system's power on the status quo.

For Example: A Z3000 MKII Smart VCO requires 50mA from the +12V rail and 25mA from the -12V rail. A hypothetical system comprising of three Z3000 MKIIs would need to source 150mA from the +12V rail and 75mA from the -12v rail to function properly.

The Zeus Studio Bus is a powered bus board, as such, it takes only the necessary amount of current needed to power the modules connected to it and not more than that. Power to the bus boards is provided by the external Tiptop-Cincon power supply. While it is good to understand the power consumption of modules as was described above, it is in most cases not necessary anymore to do the math as was the case in the previous version of Zeus power or other available power supplies. **With the Zeus Studio Bus the rules are simple, use one external power supply per 3 bus boards.** Systems that use more bus boards will use multiple external power supplies, with the same rule applied, one power supply per 3 bus boards. If however you plan on powering many digital modules then it might be worth calculating the total current consumption to make sure you are not going over the 1300mA limit of the positive 12V on each board and the total 4600mA coming from the external power supply.



Chapter 3 Attaching the Zeus Studio Bus to the case

To insert a wire use a flat head screw driver or fingers to press and hold

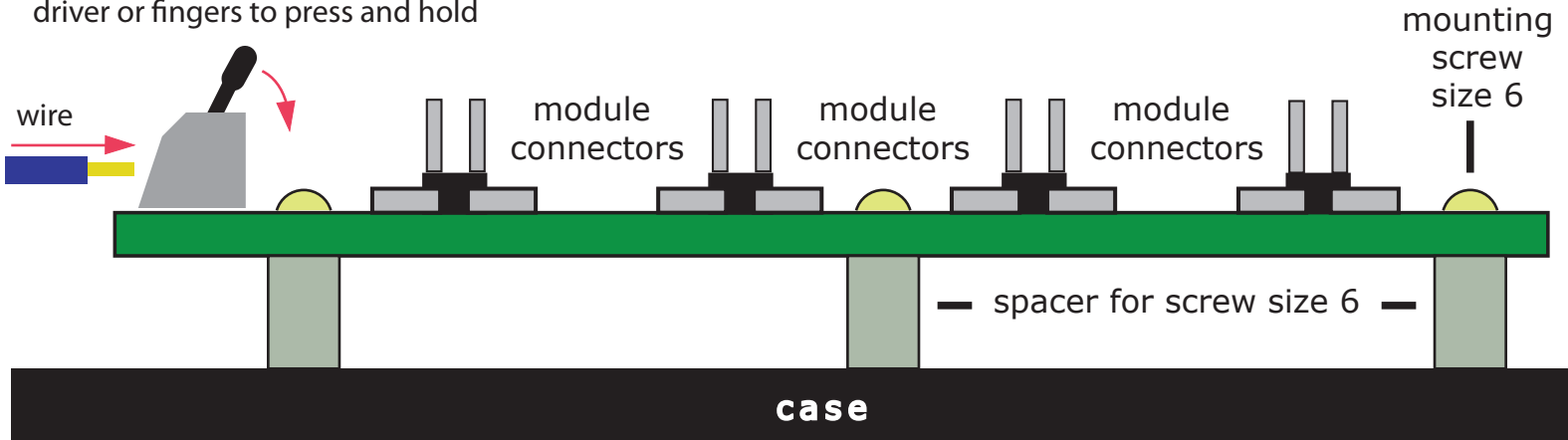

Wire: Use multi stranded 16AWG wire all across the system. The Zeus Studio Bus uses only two signals, POWER and GROUND, it is recommended to use two colors, one for each signal.

Mounting Screws: Size 6 screw - the mounting holes on the bus boards are made for screw size 6. There is no need for plastic or nylon screws, metal screws are fine to use, these can be found in most home improvement stores.

Spacer: 1/4" Spacer, we recommend using spacers with minimum height of 1/4", recommended part numbers are listed in the next page.

Under heavy load or in case of a short the Zeus Studio Bus can get hot, it is important that there is space left between the bus board and the case to give the bus board enough space for air circulation for cooling down and to keep a safe distance from any flammable material. It is also recommended that for cases with more than 3 bus boards some ventilation holes be added, this is not a must but is recommended if possible. A few 0.25" diameter holes on the top and bottom of a case are recommended.

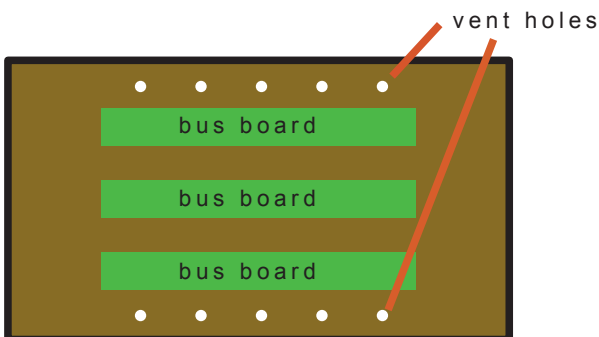



Chapter 4

List of recommended parts and part numbers

For systems of up to 3 bus boards we recommend using the Zeus Access panel interface. The Zeus Access comes equipped with a power socket, power switch and wires for a quick and easy installation of a Zeus Studio power system. It is recommended to get the Zeus Access and at least one Zeus Studio and then design the case around the wiring length of the Zeus Access.

For systems with more than 3 bus boards that will require using 2 or more external power supplies, you can either use multiple Zeus Access, Zeus Access Dual, or make your own connections. Here is a list of switches and power sockets that we recommend for using.

DC 2.5mm Power socket.
Mouser Part Numbers:

806-KLDPX-0302-B

163-4305

Toggle switch SPST:
Mouser Part Numbers:

691-DA100-PB-B

633-WT11S-RO

Toggle switch DPDT:
Mouser Part Numbers:

633-WT22S

633-S6B-RO

Toggle switch 4PDT:
Mouser Part Numbers:

691-IL250-73

Round clear hole spacer
Mouser Part Numbers:

534-885

Threaded spacer:
Mouser Part Numbers:

534-1922A



Chapter 5 The Tiptop Cincon power supply

As part of our challenge to come with a power system that can deal with the growing challenges that the eurorack synthesizer brings with its development, we had to look at every single point in the system and find ways to increase performance. One of the main components in the system is the external power supply and together with Cincon Taiwan, a leader in switch mode power supplies, we have customized a certified power supply to achieve the best performance possible for audio use. That's how we created the TTA-Cincon power supply that we recommend using with the Zeus Studio Bus.

The TTA-Cincon is a 15VDC supply that is rated at 4.6A and can be used to power up to 3 Zeus Studio Bus boards. As 4.6A are getting spread across 3 bus boards, there are hardly any chances that you will find yourself needing more power; this is a powerful power supply.

Though highly recommended for best performance, the Zeus Studio Bus is not restricted to using the TTA-Cincon power supply to operate. If you would like to power your Zeus Studio Bus using other external power supplies then please make sure to use a 15VDC power supply with at least 4.6A. Using a power supply that is higher or lower than 15VDC will damage the Zeus Studio Bus.



Chapter 6 Power up for the first time

After installing the Zeus system into a case comes the magical moment to power it up for the first time. The Zeus Studio Bus includes a built-in time delay to allow the power regulators to stabilize before they start providing power to your modules. When the Zeus board gets powered up the +5V will turn first, the +12V and -12V might take up to 0.5 second to light, **this is normal**. On first power up it is highly recommended that there will be no modules connected to the power system. Hold your hand on the power switch and get ready to shut it off in case the lights don't turn on. Give the lights 1 second to turn on, no more than that.

The Zeus Studio Bus uses high value capacitors that if connected in the wrong polarity might smoke and even blow, please make sure to keep your eyes away for at least an arm's length from the bus boards on first time power up.

If one or all lights don't turn on after 1 second, turn off the system and recheck your wiring. Also check for any other parts that might touch or short the bus board.

Chapter 7 The wire connector and grounding

Wiring up the Zeus Studio Bus board is made super easy thanks to the spring action wire connector which is located on the left side of each bus board. The Zeus Studio Bus uses only two signals, POWER and GROUND which further simplified wiring up a system. The signals on the spring connectors are as follows:

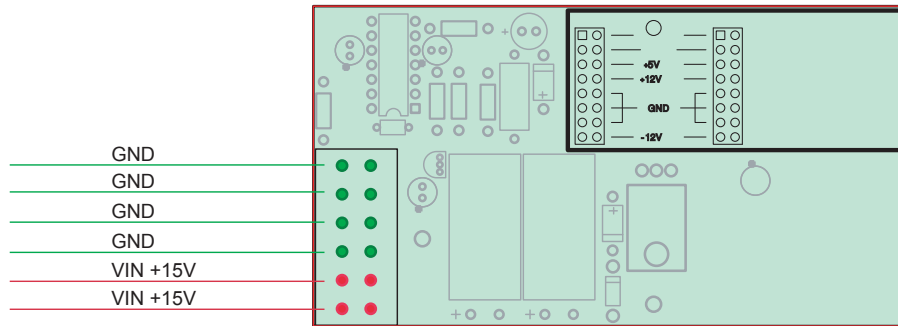

As can be seen from the drawing there are up to four ground points that can be connected and up to two 15VDC power points per board. The connection points can be used to create a star wiring using up to 6 wires per board, or can be used to cascade the boards. The Zeus Studio Bus is extremely flexible giving you a variety of configurations to choose from. In its most simple form there are two configurations to choose from: Cascading is most simple whereas multi-wire star provides the best performance. A combination of both is possible as well.

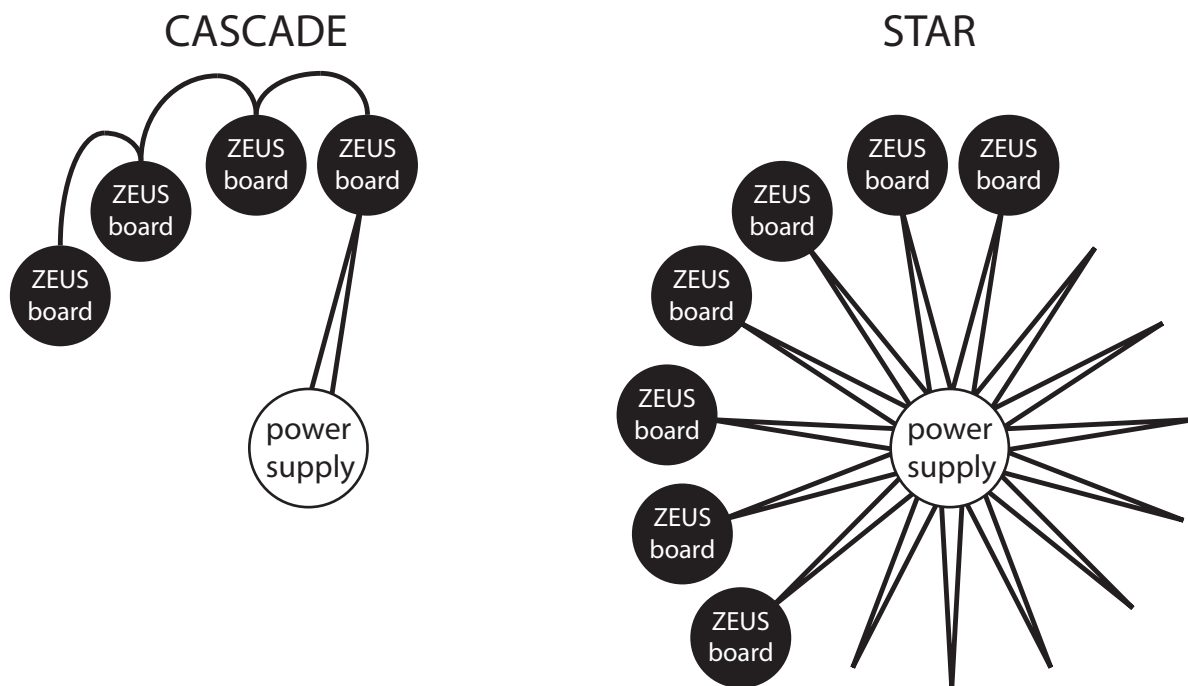

Spokes represent the ground and +15V wires running from the power supply to the bus board



Chapter 8 Planning a system.

Small systems of up to 9U will use one external power supply and up to 3 bus boards. For clarity the illustration shows only the power wire and not ground.

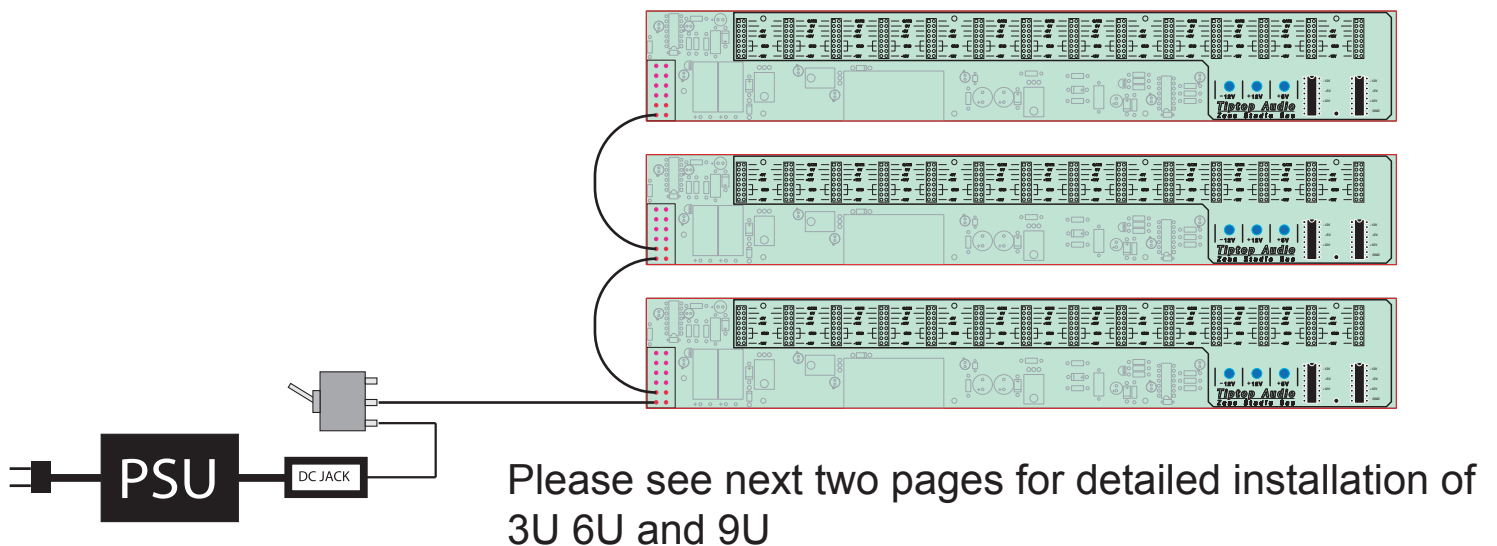
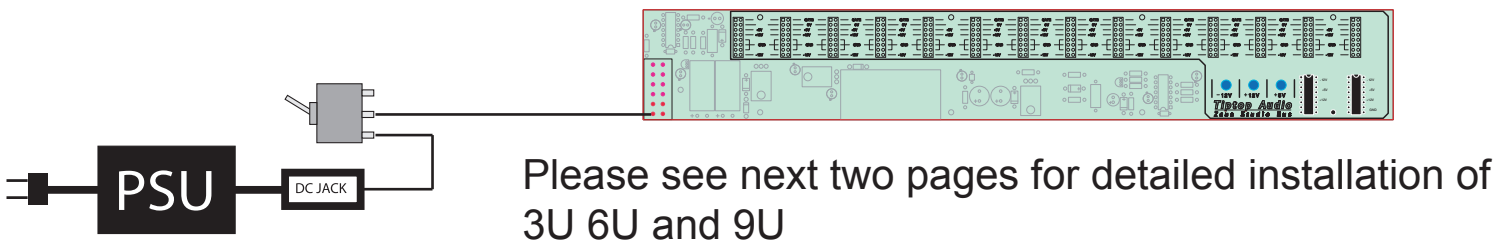



ZEUS STUDIO BUS

DETAILED WIRE DRAWING

3U AND 6U SIMPLE CASCADE WIRING

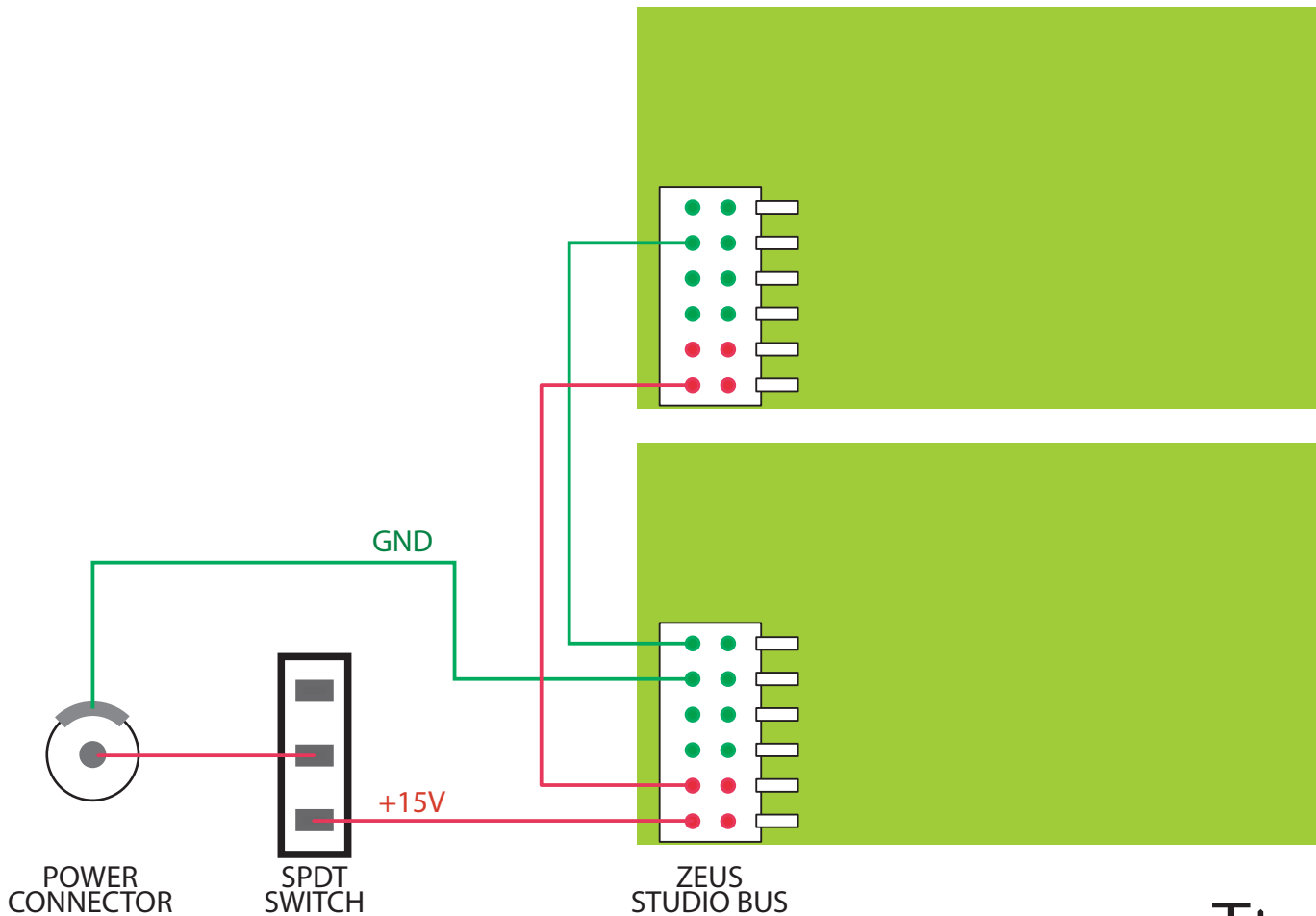
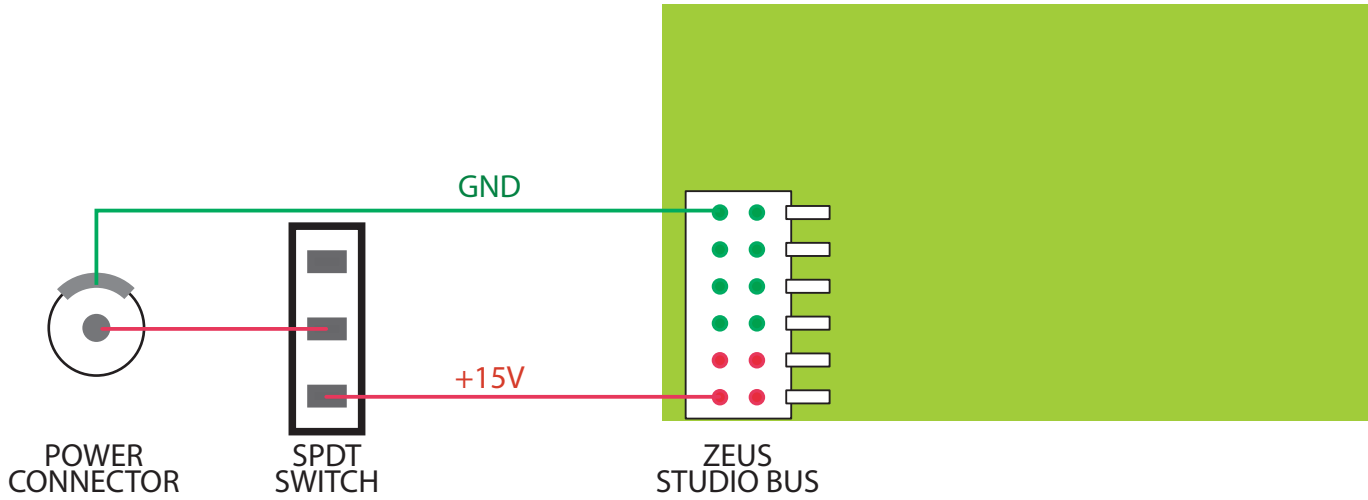



ZEUS STUDIO BUS

DETAILED WIRE DRAWING

9U SIMPLE CASCADE WIRING

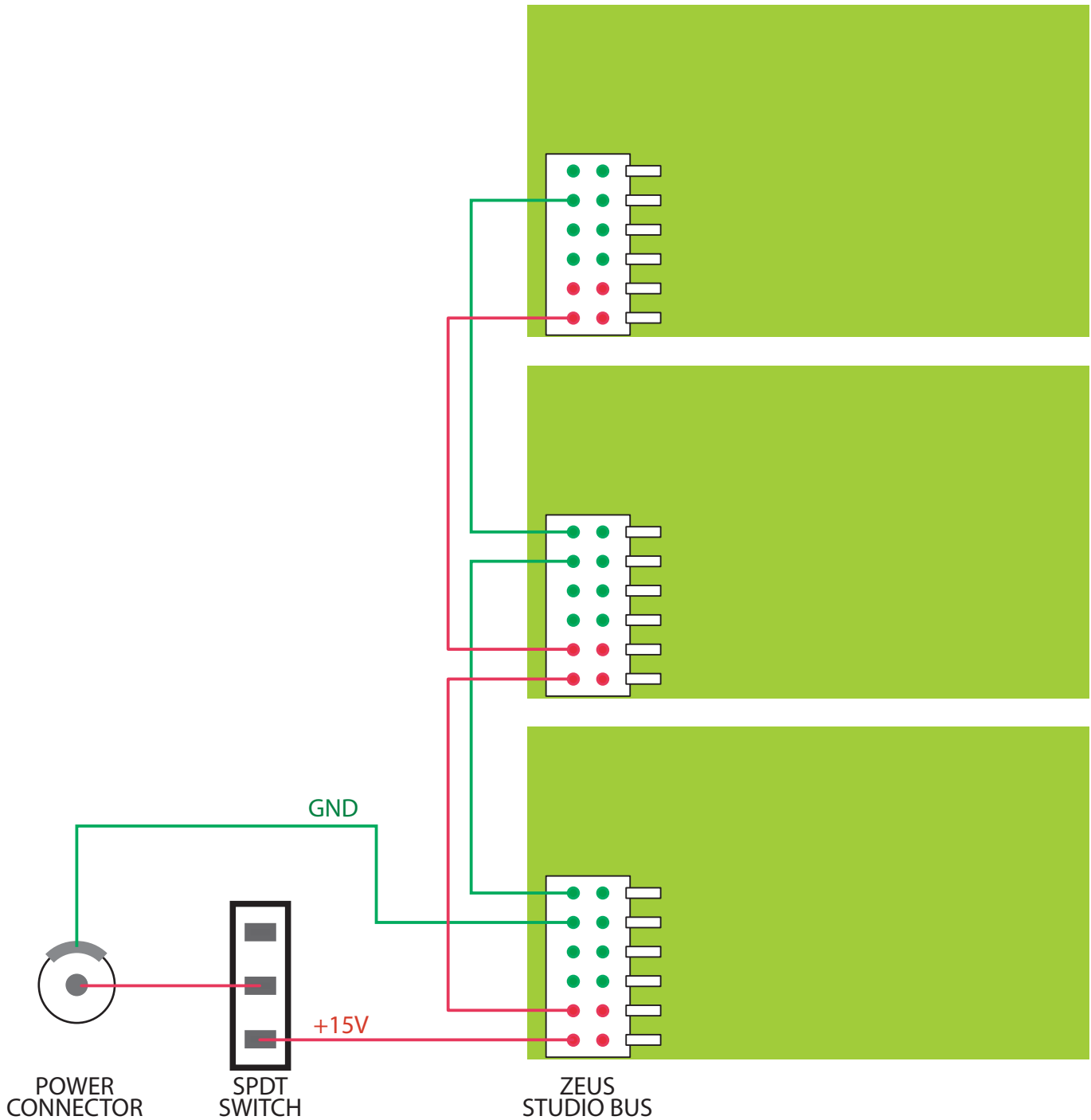



ZEUS STUDIO BUS

DETAILED WIRE DRAWING



9U PROFESSIONAL STAR WIRING WITH TWO GROUND PER BOARD

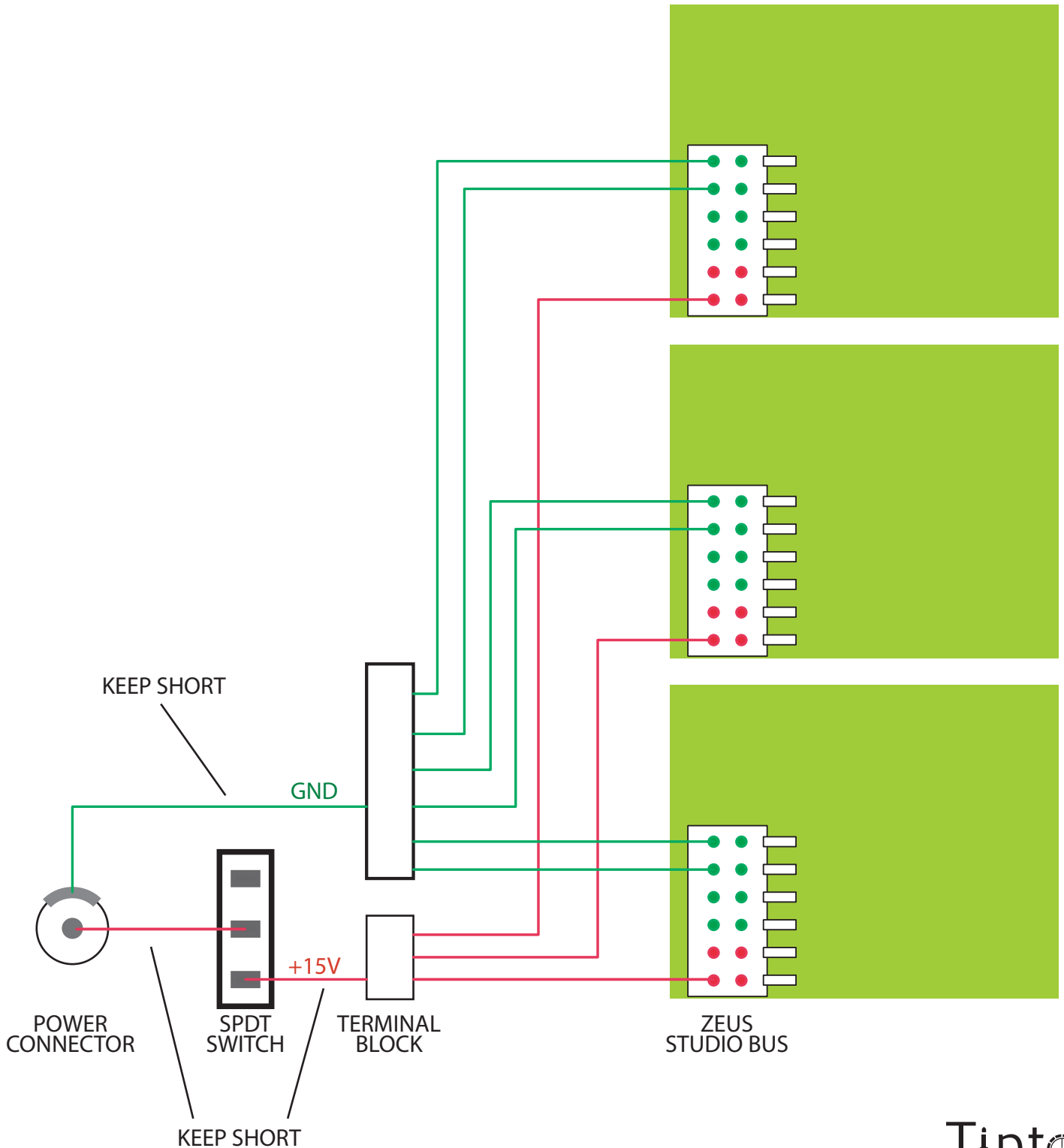



Chapter 9 Planning large systems.

Large systems from 9U and up will use multiple external power supplies, one power supply per each set of 3 bus boards. For clarity the illustration shows only the power wires and not ground.

18U

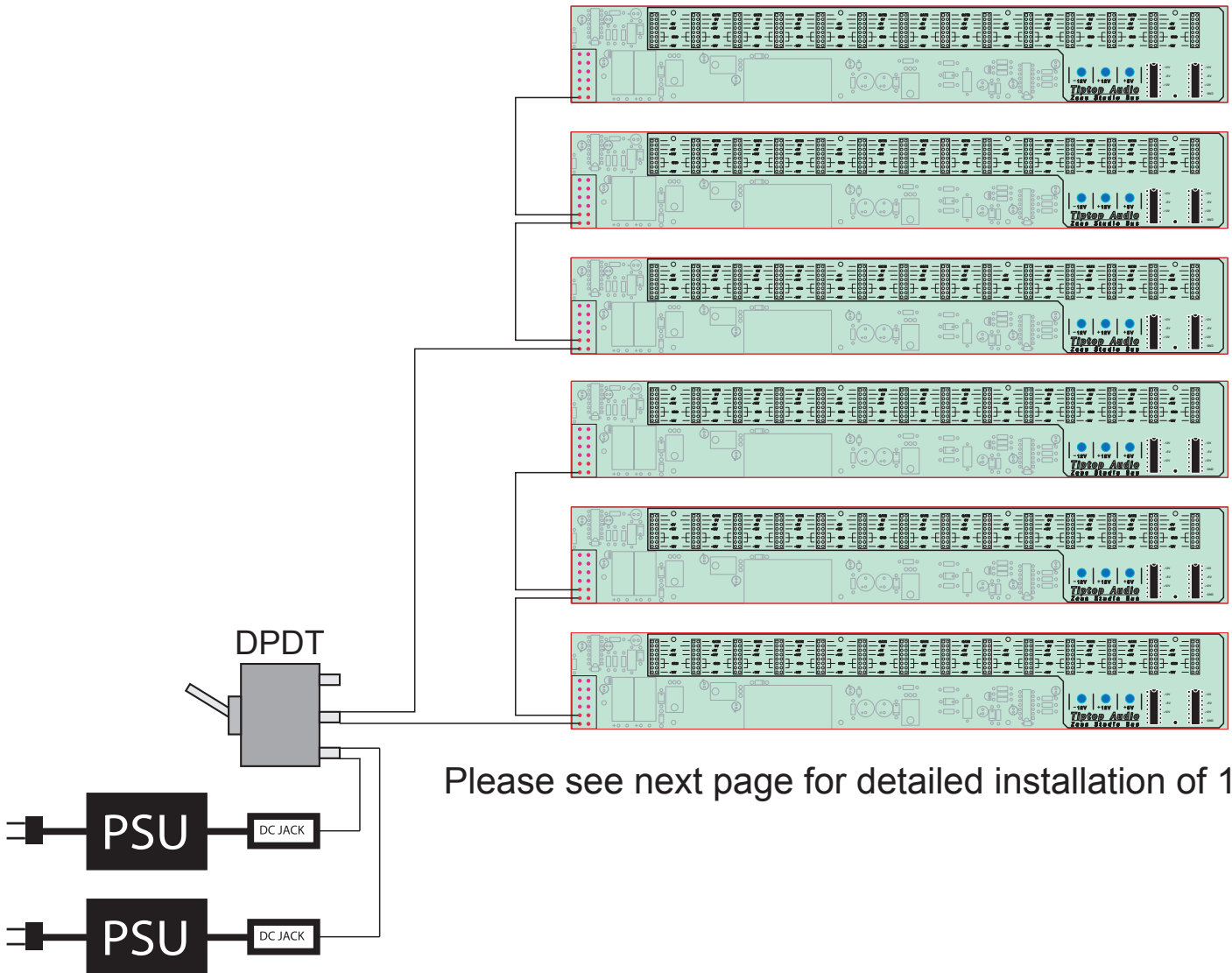

Please see next page for detailed installation of 18U



ZEUS STUDIO BUS

DETAILED WIRE DRAWING

18U SIMPLE CASCADE WIRING

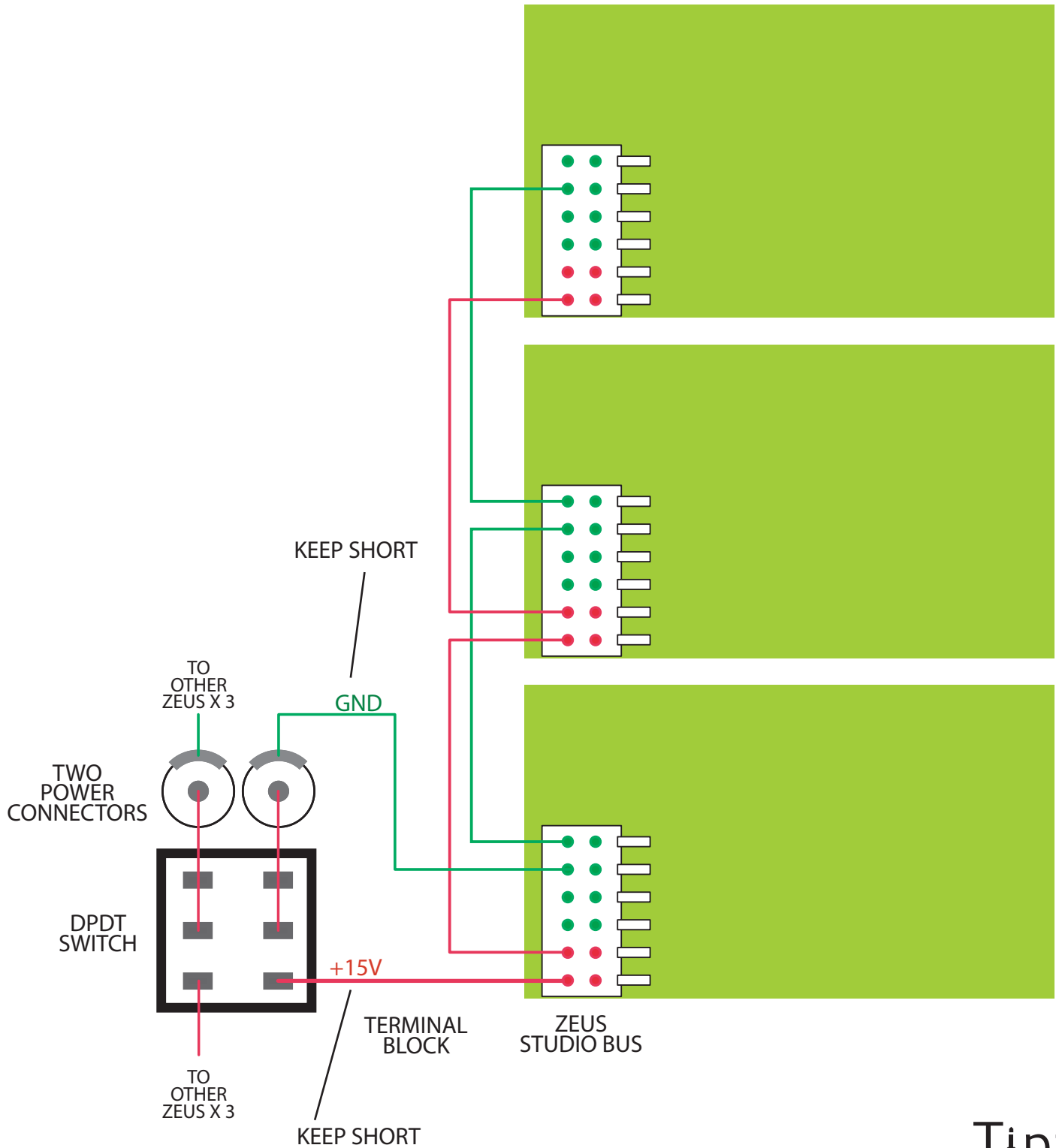



ZEUS STUDIO BUS

DETAILED WIRE DRAWING



18U PROFESSIONAL STAR WIRING WITH TWO GROUND PER BOARD

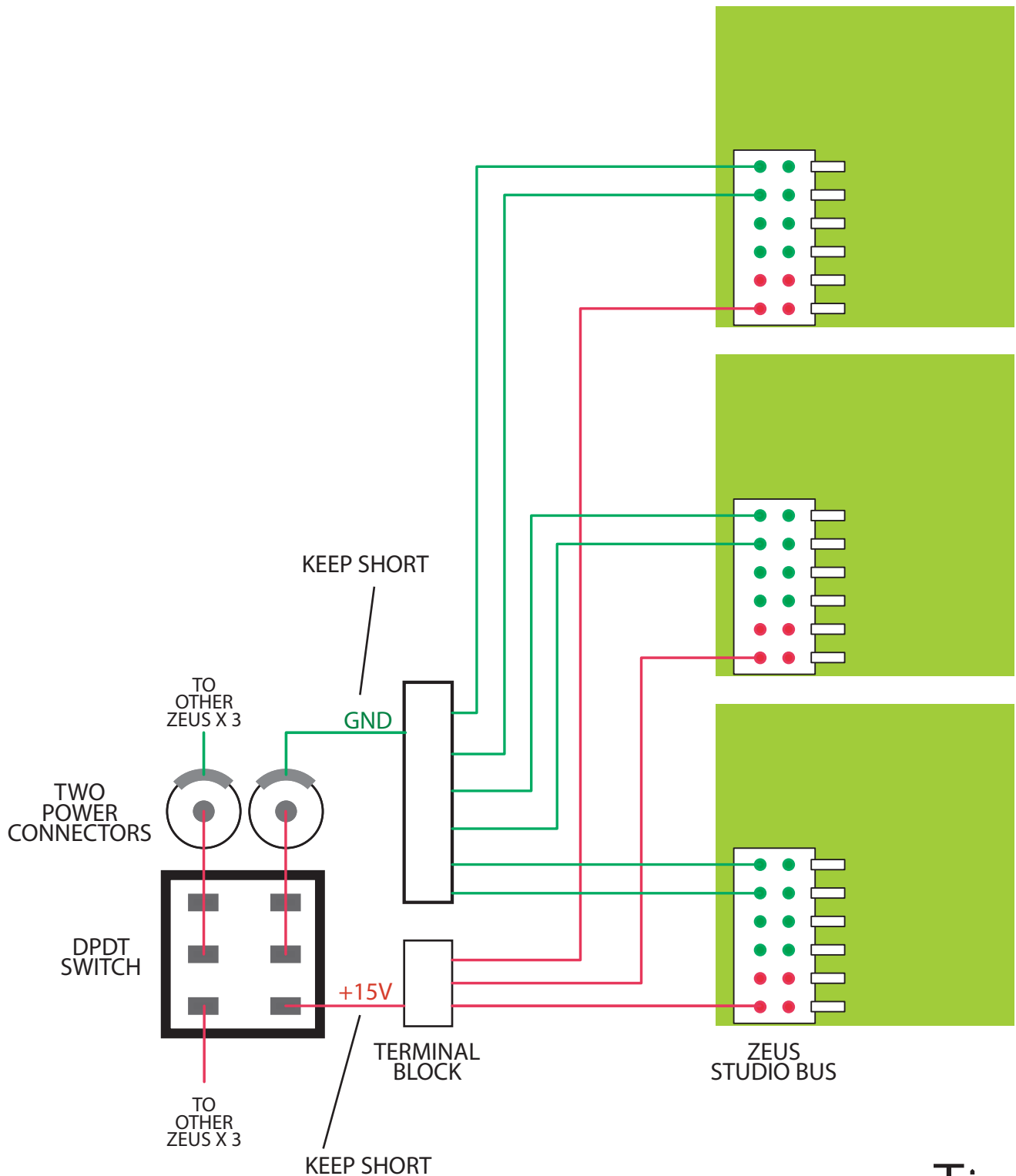



Chapter 10 Planning very large systems.

Very large systems from 18U and up will use multiple external power supplies, one power supply per each set of 3 bus boards. All boards can share a 4PDT power switch, or separate the system into two sections of 18U each with its own DPDT power switch. For clarity the illustration shows only the power wires and not ground.

18U X 2

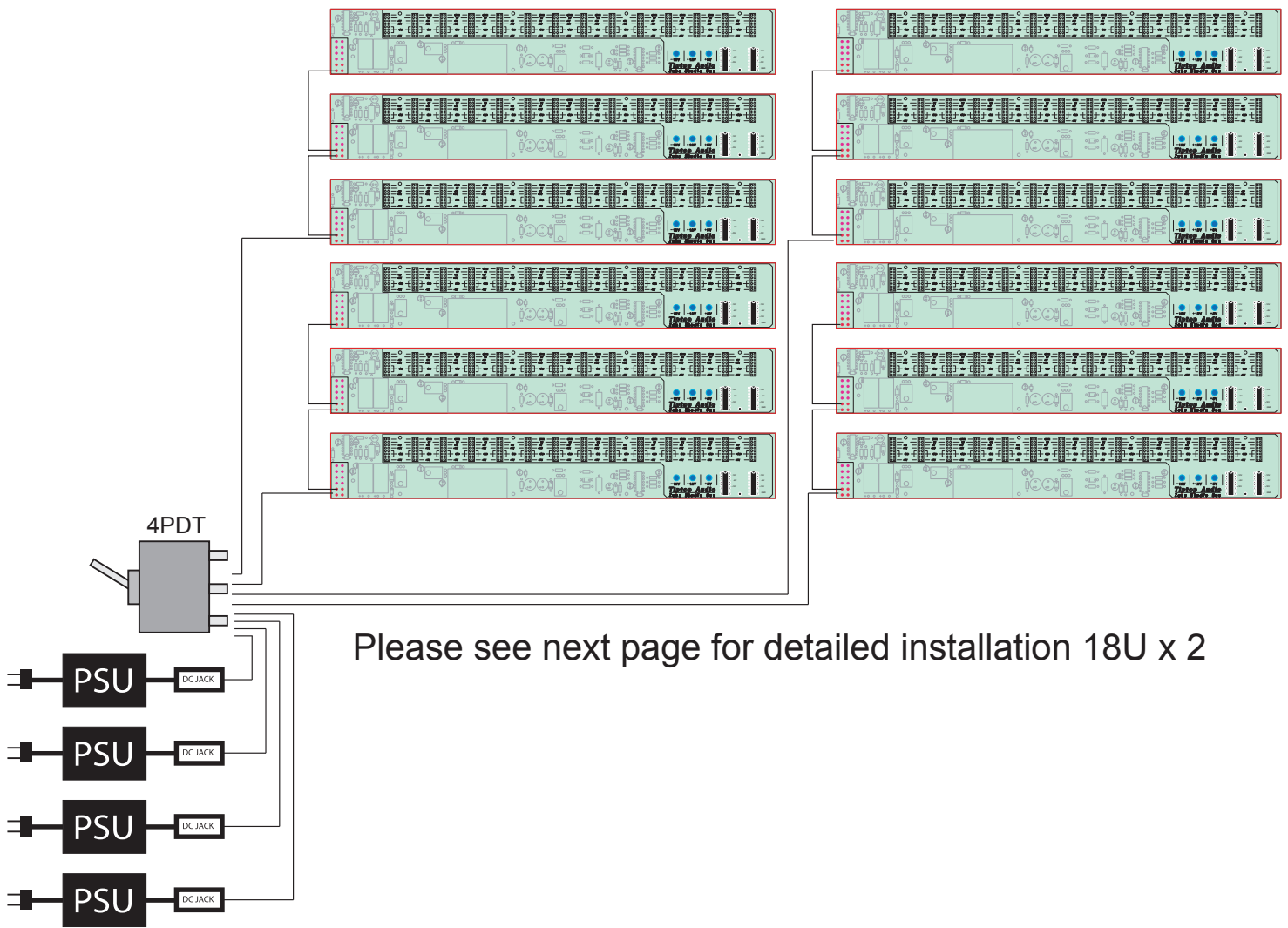

Please see next page for detailed installation 18U x 2



ZEUS STUDIO BUS

DETAILED WIRE DRAWING

18U x 2 SIMPLE CASCADE WIRING

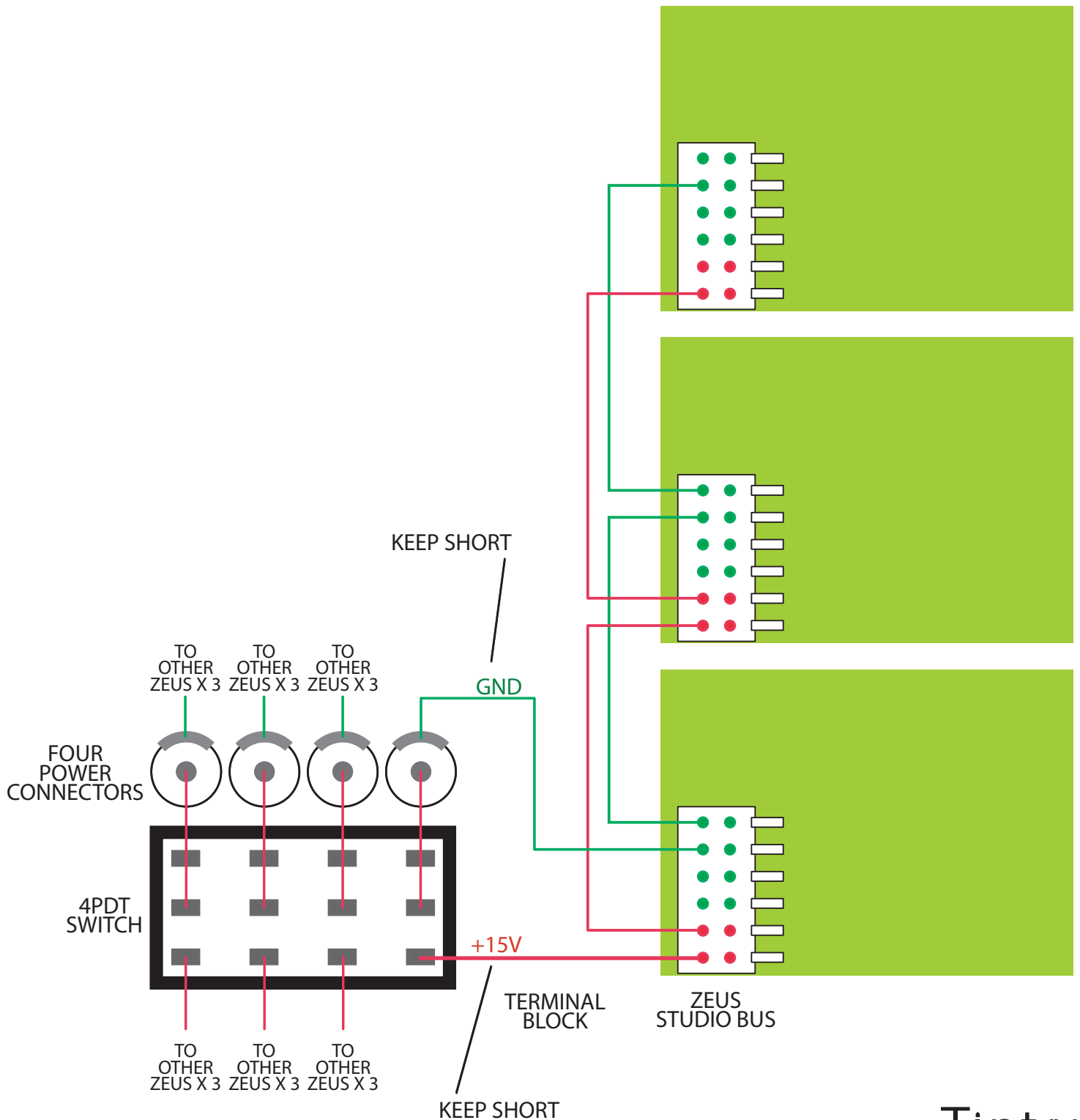



ZEUS STUDIO BUS

DETAILED WIRE DRAWING



18U X 2 WIRING STAR WITH TWO GROUND PER BOARD

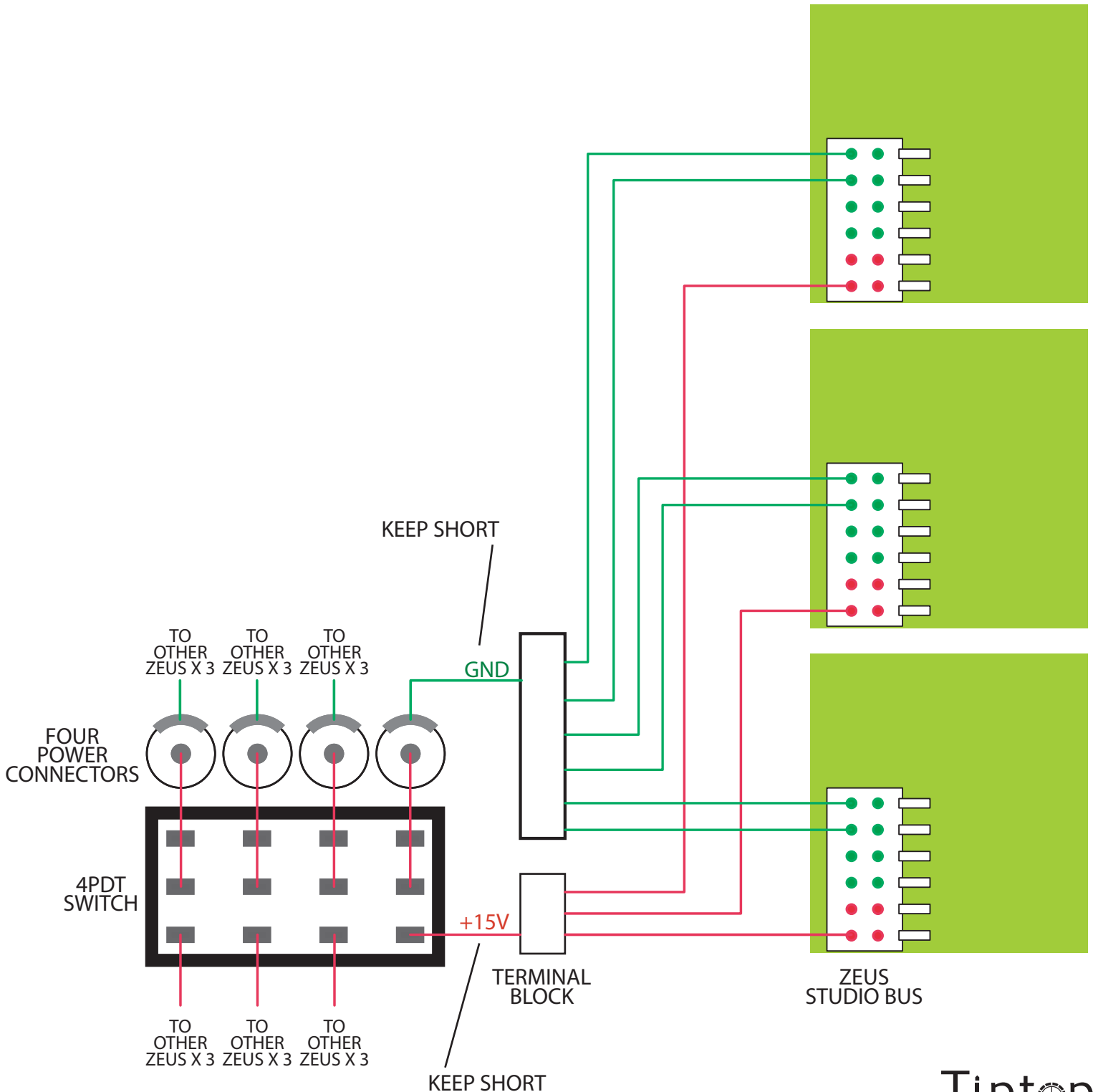

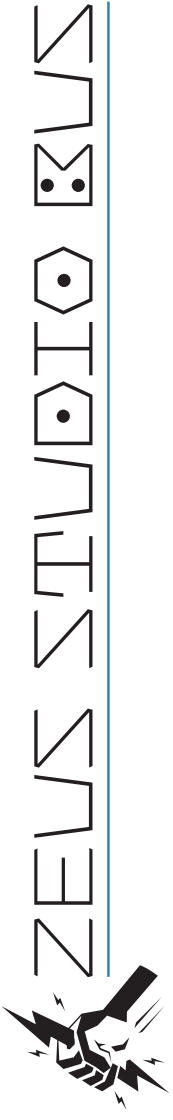

TOP VIEW

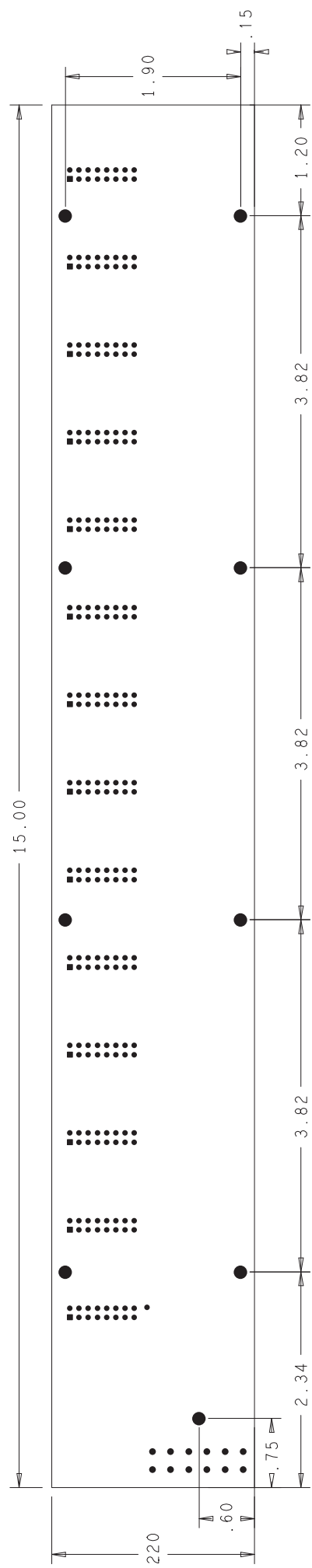

Mounting holes are 0.145"
All dimensions are in inch (imperial)



Z E U S S T U D I O B U S

Zeus Studio Bus mounting holes scaled 1:1 for print

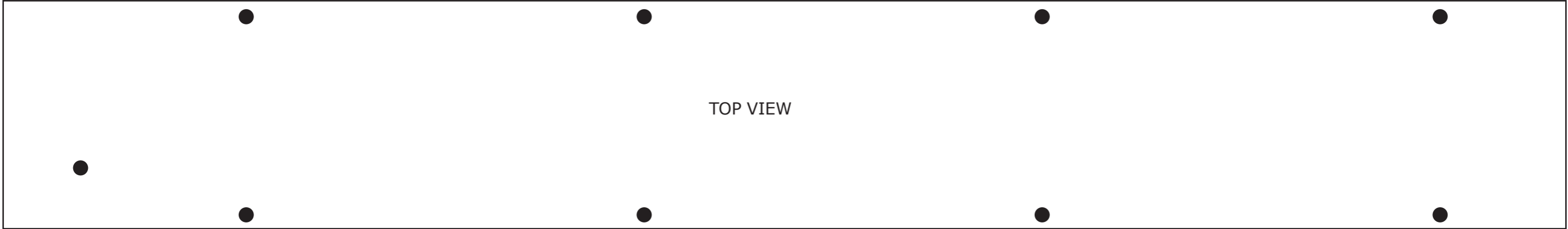

TOP VIEW



Chapter 9

Electrical specification Zeus Studio Bus (per board)

Input voltage range: +15VDC +/-10%

Output voltage: +12VDC -12VDC +5VDC

Max output current +12V: 1.3A

Max output current -12V: 800mA

Max output current +5V: 300mA

Output regulation of +/-12V: +/-0.05% Linear discrete design

Over Current protection : Yes

Shielded switcher: Yes, Tiptop Audio DC800 encapsulated switcher

Made in USA

Electrical specification Cincon-TTA power supply

Input voltage range: 100-240VAC - 1.5A 50-60Hz

Output voltage: +15VDC

Max output current: 4.6A

Over Current protection : Yes

Certification: UL level 3 , CE

Made in China

Change Log

Revision 1.1

April 5 2015:

Updated Mouser part number list of power switch.

Add a 1:1 drawing for print.