

# Quick Start Guide

## 130 DUAL VCA

Legendary Analog Dual VCA Module for Eurorack

### Controls

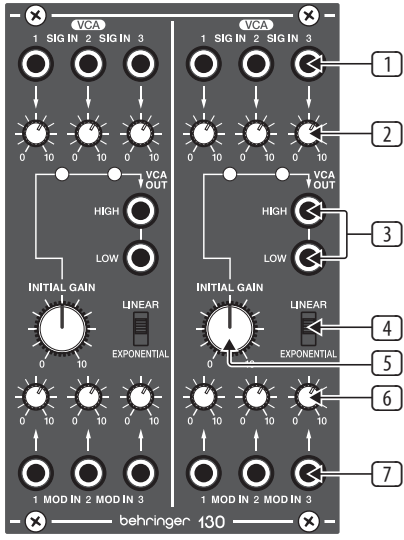

- 1 **SIG IN** input jacks accept audio signals over cables with 3.5 mm TS connectors.
- 2 **SIG IN** knobs control the gain level at the SIG IN inputs.
- 3 **VCA OUT (HIGH/LOW)** outputs connect to the inputs of external equipment over cables with 3.5 mm TRS connectors. (Note that these connections are both mono and not left/right). The HIGH mono output can be connected to the line-level inputs of mixers, keyboard amplifiers or powered speakers. The LOW output is an instrument-level signal that can be connected to the HI-Z inputs of equipment such as guitar amplifiers or mixers.
- 4 **LINEAR/EXPONENTIAL** switch toggles between linear and exponential output modes.
- 5 **INITIAL GAIN** knob controls the gain level at the VCA OUT jacks.
- 6 **MOD IN** knobs control the amount of carrier signal allowed through from the MOD IN jacks.
- 7 **MOD IN** jacks accept carrier signals from other modules (e.g., a sine wave at 500 Hz) to shape the volume envelopes and waveforms of the SIG IN signals. For these jacks, use cables with 3.5 mm TS connectors.

### Power Connection

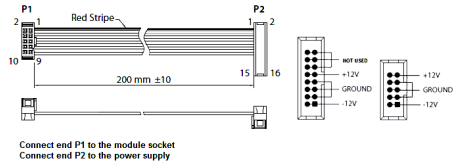

The 130 DUAL VCA comes with the required power cable for connecting to a standard Eurorack power supply system. Follow these steps to connect power to the module. It is easier to make these connections before the module has been mounted into a rack case.

1. Turn the power supply or rack case power off and disconnect the power cable.
2. Insert the 16-pin connector on the power cable into the socket on the power supply or rack case. The connector has a tab that will align with the gap in the socket, so it cannot be inserted incorrectly. If the power supply does not have a keyed socket, be sure to orient pin 1 (-12 V) with the red stripe on the cable.
3. Insert the 10-pin connector into the socket on the back of the module. The connector has a tab that will align with the socket for correct orientation.
4. After both ends of the power cable have been securely attached, you may mount the module in a case and turn on the power supply.

### Installation

The necessary screws are included with the module for mounting in a Eurorack case. Connect the power cable before mounting.

Depending on the rack case, there may be a series of fixed holes spaced 2 HP apart along the length of the case, or a track that allows individual threaded plates to slide along the length of the case. The free-moving threaded plates allow precise positioning of the module, but each plate should be positioned in the approximate relation to the mounting holes in your module before attaching the screws.

Hold the module against the Eurorack rails so that each of the mounting holes are aligned with a threaded rail or threaded plate. Attach the screws part way to start, which will allow small adjustments to the positioning while you get them all aligned. After the final position has been established, tighten the screws down.



## Specifications

### Signal Connections

Signal in	6 x 3.5 mm jack, summed
Impedance	> 50 kΩ unbalanced
Maximum input level	+18 dBu @ unity gain
VCA out high / low	4 x 3.5 mm jack
High output Impedance	1 kΩ unbalanced
Low output Impedance	3 kΩ unbalanced
High maximum output level	+18 dBu
Low maximum output level	-2 dBu
High output noise	< -66 dBu, 22 Hz - 22 kHz
Low output noise	< -86 dBu, 22 Hz - 22 kHz
Mod in	6 x 3.5 mm jack
Impedance	> 50 kΩ unbalanced
CV input range	0 V to +10 V
CV scaling in EXP mode	Typically 1 V/10 dB

### Controls

Initial gain	2 x rotary knob Linear / exponential, switchable
Sig in level	6 x rotary knob
Mod in level	6 x rotary knob
Linear / exponential CV	2 x sliding switch

### Power

Power supply	Eurorack
Current draw	30 mA (+12 V), 20 mA (-12 V)

### Physical

Dimensions (H x W x D)	44 x 81 x 129 mm (1.7 x 3.2 x 5.1")
Rack units	16 HP
Weight	0.18 kg (0.4 lbs)

### LEGAL DISCLAIMER

Music Tribe accepts no liability for any loss which may be suffered by any person who relies either wholly or in part upon any description, photograph, or statement contained herein. Technical specifications, appearances and other information are subject to change without notice. All trademarks are the property of their respective owners. Midas, Klark Teknik, Lab Gruppen, Lake, Tannoy, Turbosound, TC Electronic, TC Helicon, Behringer, Bugera, Auratone and Coolaudio are trademarks or registered trademarks of Music Tribe Global Brands Ltd. © Music Tribe Global Brands Ltd. 2019 All rights reserved.

### LIMITED WARRANTY

For the applicable warranty terms and conditions and additional information regarding Music Tribe's Limited Warranty, please see complete details online at [musictribe.com/warranty](http://musictribe.com/warranty).

### Zhongshan Eurotec Electronics Limited

No. 10 Wanmei Road, South China Modern Chinese Medicine Park,  
Nanlang Town, 528451, Zhongshan City, Guangdong Province, China